









## MULTIFUNCTION

supercook	fan forced	fan assisted	classic convection	fan grill	static grill	roisserie (optional)	baker's function	ECO — low power cooking	pyrolytic cleaning	light pyrolytic cleaning
								<b>ECO</b>	<b>P</b>	<b>ECO P</b>



finish	glass and satin stainless steel
size	597mmH x 597mmW x 566mmD
capacity	79 litre
installation	flush fitment, underbench or wallmount
cooking levels	five shelf heights plus recessed floor for pizza stone
multifunction	eight cooking functions, two pyrolytic cleaning selections
programmability	three LED displays with intuitive prompting, full auto cooking, semi-auto cooking, minute minder, manual override
menu memories	smeg Smart Chef — nine preprogrammed cooking memories, three blank memories, all amendable
cleaning	two pyrolytic self-clean selections, smeg ever-clean enamelling
lighting	automatic, two, opposite sides, staggered heights, 40-watt halogen
furniture	smeg Ever-Clean enamel — <ul style="list-style-type: none"> <li>• 20mmH grill-bake-roast tray</li> <li>• 40mmH roast tray</li> <li>• removable roof liner</li> <li>• chromed grill insert</li> <li>• one shelf</li> <li>• pair safety-grip tray handles</li> <li>• GT1P set, partial 70% telescopic shelf guides</li> </ul>
options	GT1P sets, maximum five sets GT1T sets, total 110% telescopic shelf guide, maximum five sets PRTX 35cm diameter pizza stone PAL stainless steel/timber pizza shovel roisserie attachment
warranty	two years parts and labour

### SMART CHEF

Choose between nine preset recipes — beef, lamb, pork, poultry, fish, vegetables, pizza, cakes and biscuits. The Smeg oven will advise on the best shelf height for optimum cooking results. There are also three extra memories to store family favourite recipes.

### INTUITIVE COOKING

Temperature, function, time or a fully automatic Smart Chef program are all logically reflected in the electronic LED display. If a step progression is required, the LED display highlights the next step to follow.

### NEW SMEG THERMOSEAL

This uniquely insulated and sealed oven creates the most desirable and stable environment for the cooking of food. The thermosealed state diminishes splatter and food trauma; cooking times may be reduced due to the more even temperature maintained within the oven during cooking. Most importantly, it cares for the food like no other oven.

The addition of a Venturi humidity control system assists to establish the optimum cooking environment.

### EVER-CLEAN ENAMELLING

Smeg's enamelling process is unique, creating a silky-smooth finish on oven interiors and baking trays. A combination of formulae, coating application and firing processes creates a truly superior result. The enamel finish is pyrolytic quality and is used on all models, both standard and pyrolytic, in the range.

### PYROLYTIC CLEANING

The pyrolytic function enables the oven to reach an internal temperature of 500°C, whereupon all residual food debris is carbonised into a superfine dust. This superheating barely affects the outside surface temperature and, for absolute safety, the oven locks and unlocks itself during the process.

### LARGE 68-LITRE CAPACITY

Clever engineering and design has now delivered a 68-litre true net cooking capacity (up from 56 litres) over five shelf levels. The recessed enamel floor will accommodate an optional Smeg pizza stone.

### COOL DOOR

The new oven doors are all at least triple glazed; pyrolytic model ovens have four layers of glazing. Each layer of glass has a thermo-reflective inner face to limit the absorption and eventual transference of heat to the outside surface. Each inner layer is separated by an air gap through which the tangential fan channels forced air through each layer of glass — resulting in the oven door maintaining a safe low temperature, cool enough to touch and cooler kitchen environment.

### TELESCOPIC SHELVING

Each shelf level is capable of being partially or totally telescoped forward to a flat plane for easy access. Partial (70%) and total (110%) guides are available as accessories.

# SAP112-8

## Smeg thermosealed and pyrolytic electric oven, Linear design

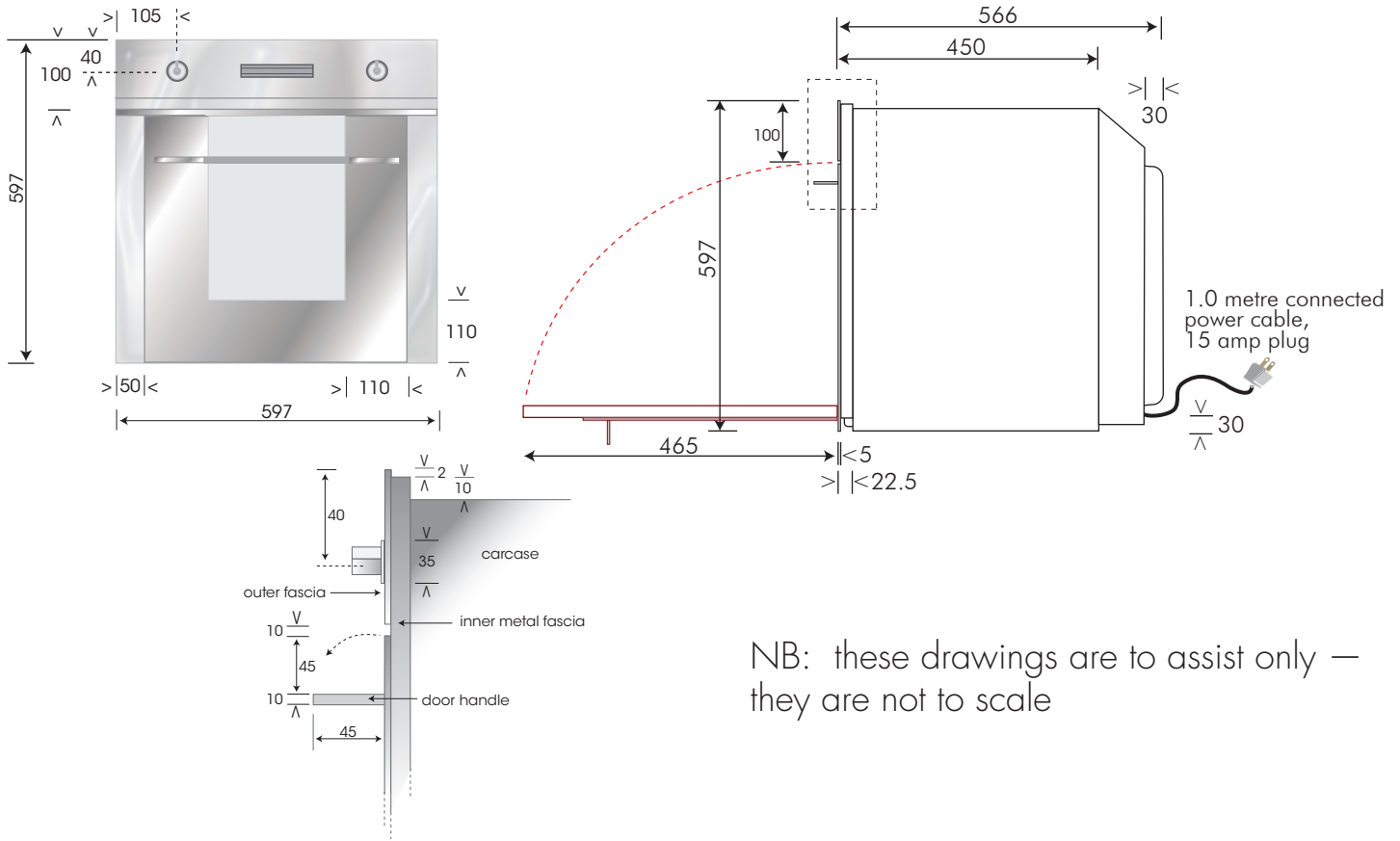

NB: these drawings are to assist only — they are not to scale

element	roof		floor	rear wall	rear wall fan	cooling fan	roisserie	light, 2 x halogen	consumption	
	inner	outer							max wattage	current
wattage	1700	1000	1200	2000	25	32	25	2 x 40		
supercook		500	600	●	●	●		●	3237	15.49
fan forced				●	●	●		●	2137	8.91
fan assisted		●	●		●	●		●	2337	9.74
classic convection		●	●			●		●	2312	9.64
fan grill	●	●			●	●		●	2837	11.83
static grill	●	●				●		●	2812	11.72
baker's function			●		●	●		●	1337	5.58
low energy cooking <b>ECO</b>		900	1000		●	●		●	2037	8.49
pyrolytic cleaning <b>P</b>		500	600	●	●	●		●	3237	15.49
light pyrolytic cleaning <b>ECO P</b>		500	600	●	●	●		●	3237	15.49
roisserie	●	●				●	●	●	2837	11.82